

Video inserter

RL4-MIB92

Compatible with

VW vehicles with MIB2 High - Discover Pro infotainment and 9.2inch monitor

Skoda vehicles with MIB2 High – Columbus infotainment and 9.2inch monitor



Example MIB2 High Discover Pro

Video-inserter for front- and rear-view camera and two additional video inputs

Product features

- Video-inserter for factory-infotainment systems
- 1 CVBS Input for rear-view camera
- 1 CVBS Input for front camera
- 2 CVBS Video-inputs for after-market Video sources (e.g. USB-Player, DVB-T2 Tuner)
- Automatic switching to rear-view camera input on engagement of the reverse gear
- Automatic front camera switching after reverse gear for 10 seconds
- Activatable parking guide lines for rear-view camera (not available for all vehicles)
- Video-in-motion (ONLY for connected video-sources)
- Video-inputs NTSC and PAL compatible

Contents

1. Prior to installation

- 1.1. Delivery contents
- 1.2. Checking the compatibility of vehicle and accessories
- 1.3. Boxes and connectors – video interface
- 1.4. Settings - 8 Dip switches (black)
 - 1.4.1. Activating the front camera (dip 1)
 - 1.4.2. Enabling the interface's video inputs (dip 2-3)
 - 1.4.3. Rear-view camera setting (dip 5)
 - 1.4.4. Activating the guide lines (dip6)
 - 1.4.5. Activation of the Interface PDC Graphic (Dip 7)
 - 1.4.6. Activation of the manual image adjustment in the menu (Dip 8)
- 1.5. Settings - 4 Dip switches (CAN function – red)
- 1.6. Settings - 2 Dip switches (Selection head-unit – black)

2. Installation

- 2.1. Place of installation
- 2.2. Connection schema
 - 2.2.1. Connection – factory head-unit
 - 2.2.2. Connection - Power
 - 2.2.3. Analog power supply
 - 2.3. Power supply output
- 2.4. Connection - video-sources
 - 2.4.1. Audio insertion
 - 2.4.2. After-market front camera
 - 2.4.3. After-market rear-view camera
 - 2.4.3.1. Case 1: Interface receives the reverse gear signal
 - 2.4.3.2. Case 2: Interface does not receive the reverse gear signal
- 2.5. Connection - video-interface and external keypad
- 2.6. Picture -, guide-lines- and PDC settings

3. Interface operation

- 3.1. By factory infotainment button
- 3.2. By keypad

4. Specifications

5. FAQ – Trouble Shooting-Interface functions

6. Technical support

Legal Information

By law, watching moving pictures while driving is prohibited, the driver must not be distracted. We do not accept any liability for material damage or personal injury resulting, directly or indirectly, from installation or operation of this product. Apart from using this product in an unmoved vehicle, it should only be used to display fixed menus or rear-view-camera video when the vehicle is moving (for example the MP3 menu for DVD upgrades).

Changes/updates of the vehicle's software can cause malfunctions of the interface. Up to one year after purchase we offer free software-updates for our interfaces. To receive a free update, the interface has to be sent in at own cost. Wages for de-and reinstallation and other expenditures involved with the software-updates will not be refunded.

1. Prior to installation

Read the manual prior to installation. Technical knowledge is necessary for installation. The video interface's place of installation must be free of moisture and away from heat sources.

Before the final installation in the vehicle of the video sources, we recommend a test-run to ensure the compatibility of vehicle and interface. Due to changes in the production of the vehicle manufacturer there's always a possibility of incompatibility.

1.1. Delivery contents

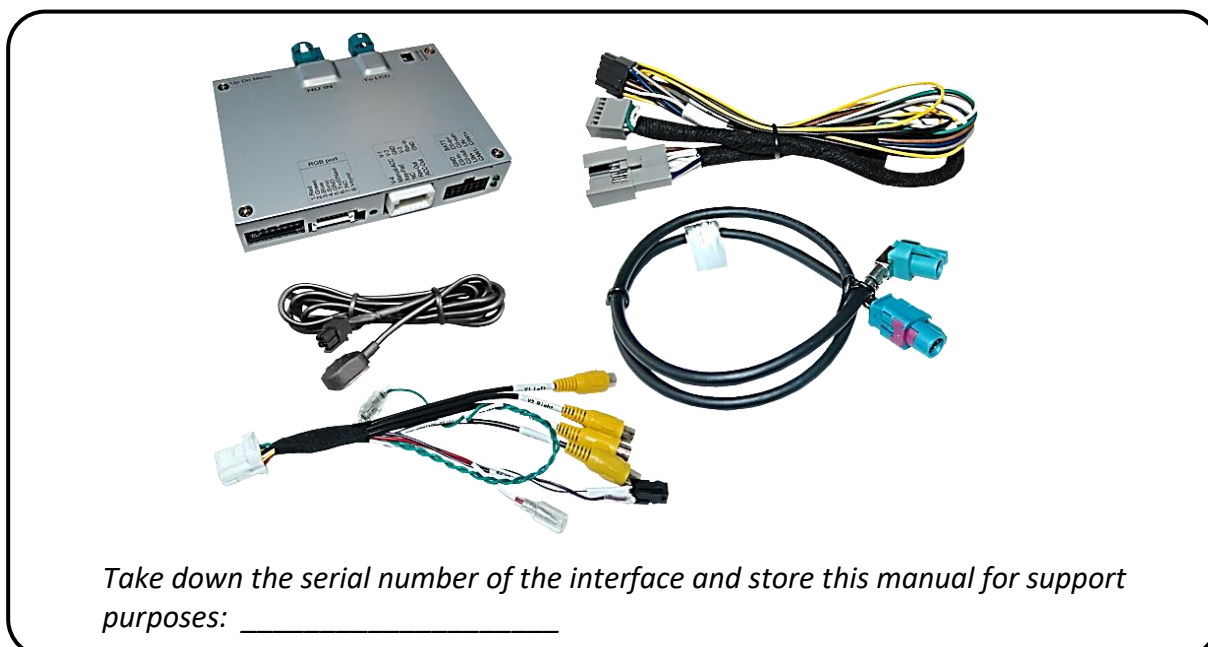

1.2. Checking the compatibility of vehicle and accessories

| Requirements | | |
|--------------|--|--|
| Brand | Compatible vehicles | Compatible systems |
| Seat/Cupra | Arona (KJ7) since MY 2022 Ateca (KH7) since MY 2021 Ibiza (KJ) since MY 2022 | MIB2 High und MIB3 High – Media System Plus Only with 9.2inch monitor |
| Skoda | Fabia3 (NJ) MY since 2018 Kamiiq (NW4) since 06/2019 Karoq (NU7) MY since 2018 Kodiaq (NS7) MY since 2018 Octavia3 (5E) MY since 2018 Superb3 (3V) MY since 2018- | MIB2 High und MIB3 High - Columbus Only with 9.2inch monitor |
| VW | Arteon (3H) MY since 2018 Golf7 (SQ) MY since 2018 Golf7 Sportsvan MY 2018-2020 Passat (B8) MY since 2018 Tiguan2 (AD1) since MY 2018 Touran (5T) MY since 2018- Touareg3 (CR) since 07/2018 Transporter T6.1 (SH) since MY2020 | MIB2 High und MIB3 High- Discover Pro Only with 9.2inch monitor |

| Limitations | |
|----------------------------------|--|
| <i>Video only</i> | The interface inserts ONLY video signals into the infotainment. For inserting Audio signals either the possibly existing factory audio-AUX-input or a FM-modulator can be used. If 2 audio sources shall be connected to the infotainment, an additional electronic is necessary to switch them. |
| <i>After market front camera</i> | The front camera will automatically be switched for 5 seconds after disengaging the reverse gear. A manually front camera switching is possible by external keypad. |
| <i>Factory rear-view camera</i> | Automatically switching-back from inserted video to factory rear-view camera is only possible while the reverse gear is engaged. To delay the switch-back an additional electronic part is required. |
| <i>PDC and guidelines</i> | If the video interface does not receive the required information from the vehicle CAN-bus, neither guide-lines nor optical PDC display will be supported. |

1.3. Boxes and connectors – video interface

The video-interface converts the video signals of connected after-market sources in a factory monitor compatible picture signal which is inserted in the factory monitor, by using separate trigger options. Further it reads the vehicle's digital signals out of the vehicle's CAN-bus and converts them for the video interface.

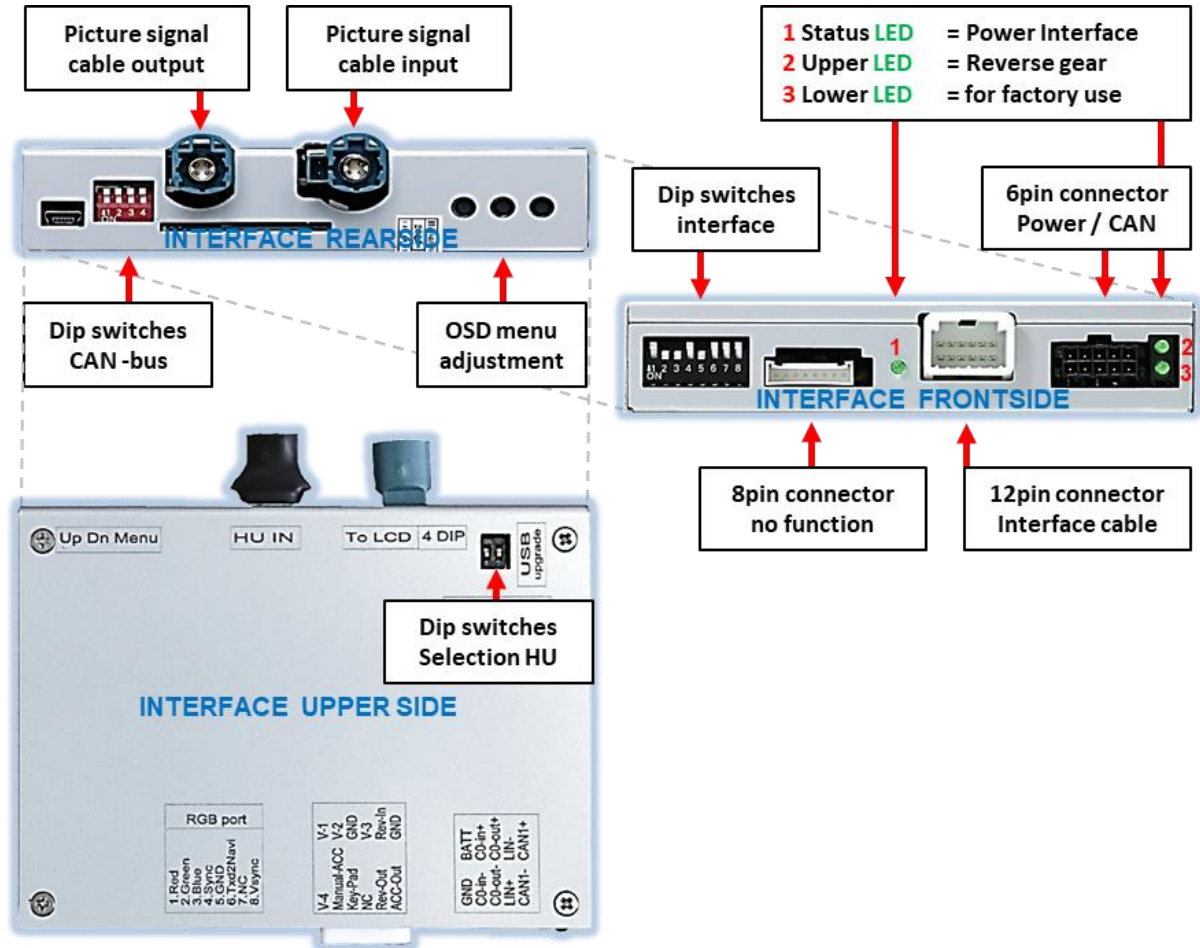

1.4. Settings - 8 Dip switches (black)

Some settings have to be selected by the dip-switches on the video interface. Dip position down is ON and position up is OFF.



| Dip | Function | ON (down) | OFF (up) |
|-----|--------------------------------|---|--------------------|
| 1 | Front camera | enabled* | disabled |
| | Power supply output (red wire) | +12V (max. 3A) when reverse gear is engaged incl. 10 seconds delay and +12V by manual switching to front camera by keypad | +12V (max. 3A) ACC |
| 2 | Video 1-input | enabled | disabled |
| 3 | Video 2-input | enabled | disabled |
| 4 | No function | | set to OFF |
| 5 | Rear-view cam type | after-market | factory or none |
| 6 | Guide-lines | enabled | Auf OFF stellen |
| 7 | PDC | enabled | disabled |
| 8 | Manual picture settings* | enabled | disabled |

*The front camera will automatically be switched for 10 seconds after disengaging the reverse gear.

* see also chapter "Picture settings and guide lines".

After each Dip-switch-change a power-reset of the Video interface has to be performed!

See the following chapters for detailed information.

1.4.1. Activating the front camera (dip 1)

If set to ON, the interface switches for 10 seconds from the rear-view camera to the front camera input after having disengaged the reverse gear. In addition, a manual switch-over to the front camera input is possible via keypad (short press) from any image mode.

Description of the power supply output: see chapter "Power supply output".

1.4.2. Enabling the interface's video inputs (dip 2-3)

Only the enabled video inputs can be accessed by switching through the interface's video sources. It is recommended to enable only the required inputs, as the disabled inputs will be skipped while switching through the video interfaces inputs.

Note: Dip 4 is out of function and has to be set to **OFF!**

1.4.3. Rear-view camera setting (dip 5)

If set to OFF, the interface switches to factory picture while the reverse gear is engaged to display factory rear-view camera or factory optical park system picture.

If set to ON, the interface switches to its rear-view camera input while the reverse gear is engaged.

1.4.4. Activating the guide lines (dip6)

If set to ON, the guide-lines will be shown on the display.

If set to OFF, the guide lines won't be visible on the display.

Note: If there is no communication between interface and the vehicle's CAN-bus (several vehicles aren't compatible), the reverse gear guide-lines can't be shown during the vehicle's operation, even if they once appear after having switched the system to powerless!

1.4.5. Activation of the factory Interface PDC Graphic (Dip 7)

Dip 7 is used to display the interface PDC graphic as „picture in picture“ in combination with the camera image.

1.4.6. Activation of the manual image adjustment in the menu (Dip 8)

Dip-8 aktiviert die im Menü vertikale und horizontale manuelle Einstellbarkeit der Bildposition falls diese im Display nicht automatisch einwandfrei dargestellt wird. Mit Dip-8 in der OFF Position ist die manuelle Einstellung im Menü nicht möglich (siehe hierzu auch Kapitel „Bildeinstellungen, Führungslinien und PDC“.

1.5. Settings of the 4 Dip switches (CAN functions – red)

The 4 dip-switches of the video are used to select the head unit and the vehicle.

Dip position down is ON and position up is OFF.

| Fahrzeug/Navigation | Dip 1 | Dip 2 | Dip 3 | Dip 4 |
|---------------------|-------|-------|-------|-------|
| Alle Fahrzeuge | OFF | OFF | OFF | OFF |

Set all 4 dips to OFF position.



1.6. Settings of the 2 Dip switches (selection head unit - black)

The 2 dip switches on the upper side of the interface box are used to select the head unit.



Warning! Dip position up is ON and position down is OFF (vice versa to the black 8 dips and the red 2 dips).

| Head Unit | Dip 1 | Dip 2 |
|----------------|-------|-------|
| Alle Fahrzeuge | ON | ON |

Set both dips to ON position.



2. Installation

To install the interface, first switch off the ignition and disconnect the vehicle's battery. Please read the owner's manual of the car, regarding the battery's disconnection! If required, enable the car's Sleep-mode (hibernation mode)

In case the sleep-mode does not succeed, the disconnection of the battery can be done with a resistor lead.

If the necessary stabilized power supply for the interface is not taken directly from the battery, the chosen connection has to be checked for being constantly stable.

The interface needs a permanent 12V source!

2.1. Place of installation

The interface is supposed to be installed at a suitable location behind the vehicle's head-unit.

2.2. Connection schema

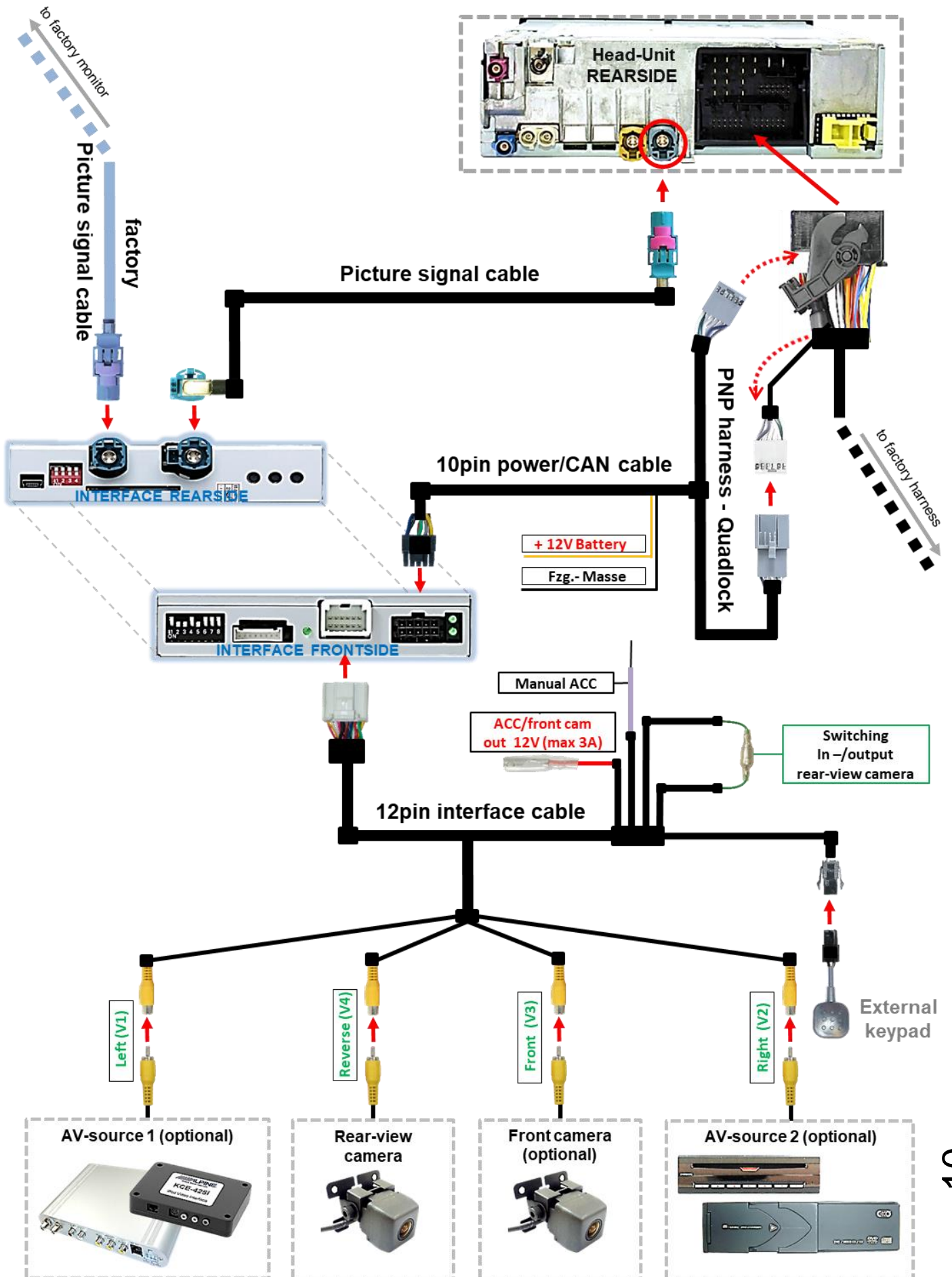

2.2.1. Connection – factory head-unit

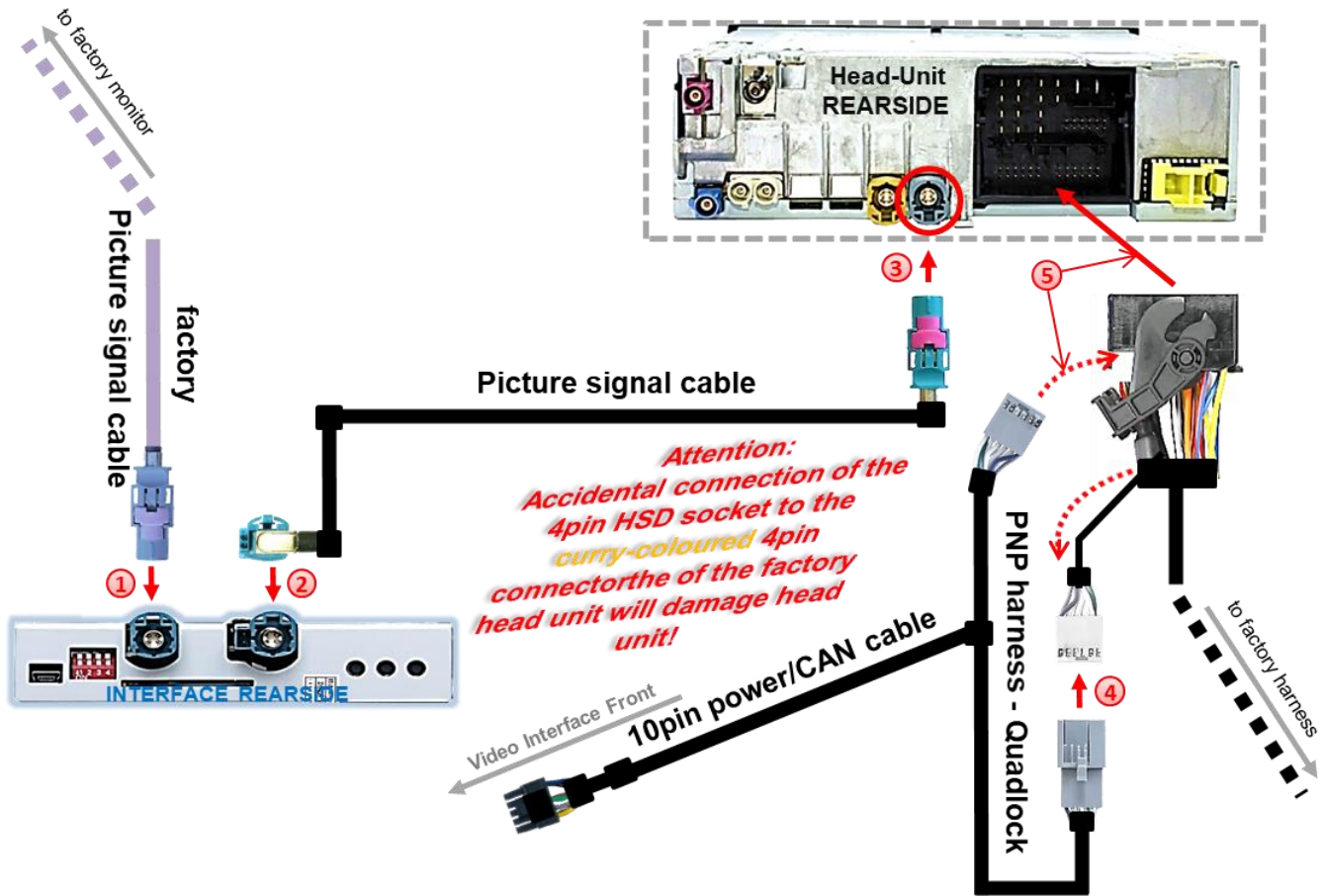

- 1 Disconnect the female 4pin HSD connector of the vehicle harness at the Rear-side of the head-unit and connect it to the interface's male 4pin HSD connector „To LCD“.

Note: If required, the marked lugs of the female 4pin HSD connector have to be cut off! Further, the colour of the female 4pin HSD connector may vary between **pink** and **grey**, depending on the installed monitor.



- 2 Connect the female HSD+2 connector of the enclosed 4pin HSD picture signal cable to the video-interface's male HSD+2 connector "HU IN".
- 3 Connect the female 4pin HSD connector of the enclosed 4pin HSD picture signal cable to the previously become free male 4pin HSD connector of the head-unit (**colours may vary!**).

- 4 Remove the female Quadlock connector of the vehicle harness from the rear of the head-unit and connect the previously clipped out white female 12pin connector (see graphic) to the male 12pin connector of the enclosed PNP harness.

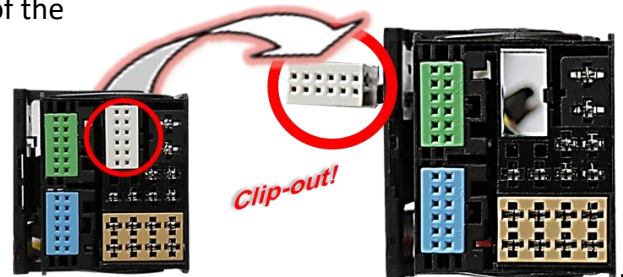

- 5 Clip in the female 12pin connector of the PNP harness in the previously become free position of the female Quadlock connector, before finishing the Quadlock reconnection at the rear of the head-unit.

2.2.2. Connection - Power

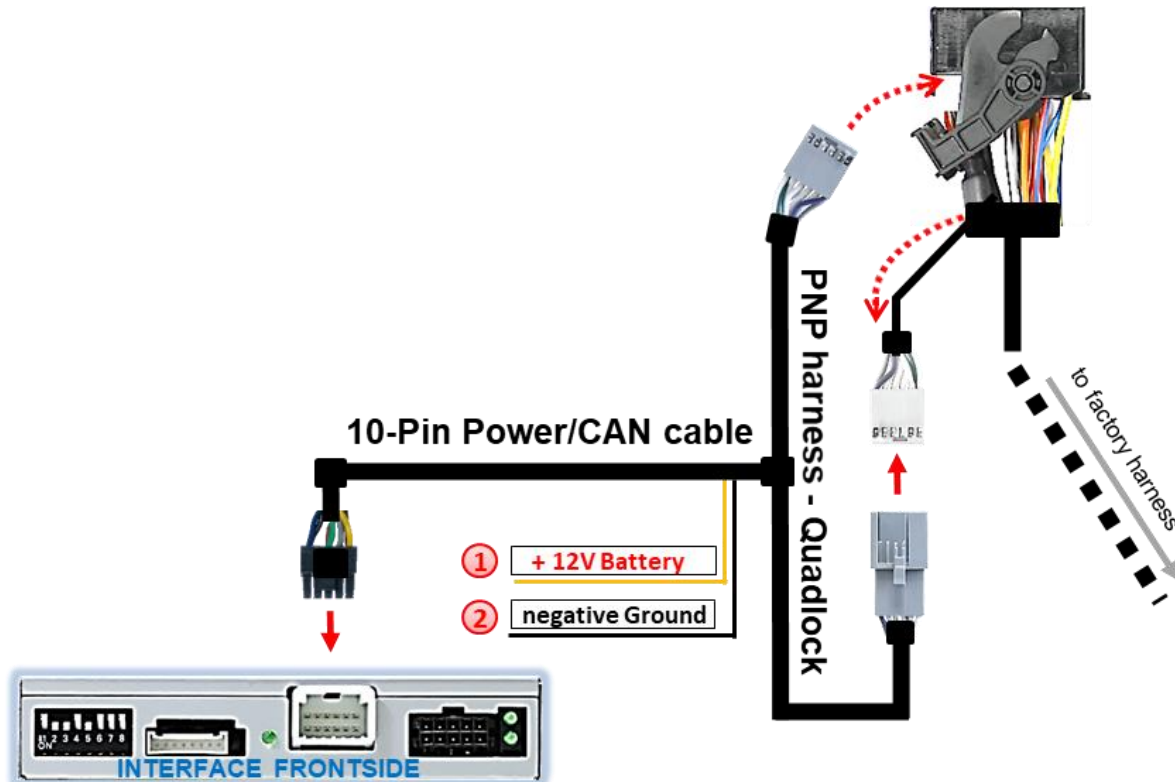

- 1 Connect the single yellow wire of the 10pin power/CAN cable to +12V permanent and stabile power supply.
- 2 Connect the single black wire of the 10pin power/CAN cable to the vehicle's negative ground.

Note: If, after connecting the 10pin Power / CAN cable, no interface LED lightens up while the ignition is turned on, refer to chapter "Analogue power supply for the video interface".



Check 1

Exceptionally, the CAN communication may not succeed in all vehicles! If, after connecting the PNP harness, no interface LED lightens up while the ignition is turned on, additionally the analog power supply needs to be done! (see following chapter)

Check 2

Exceptionally, the power supply to the video interfaces may not be interrupted after switching to the vehicle's sleep mode. If the interface LEDs continue to shine even in the vehicle's sleep mode, please contact the support!

2.2.3. Analog power supply

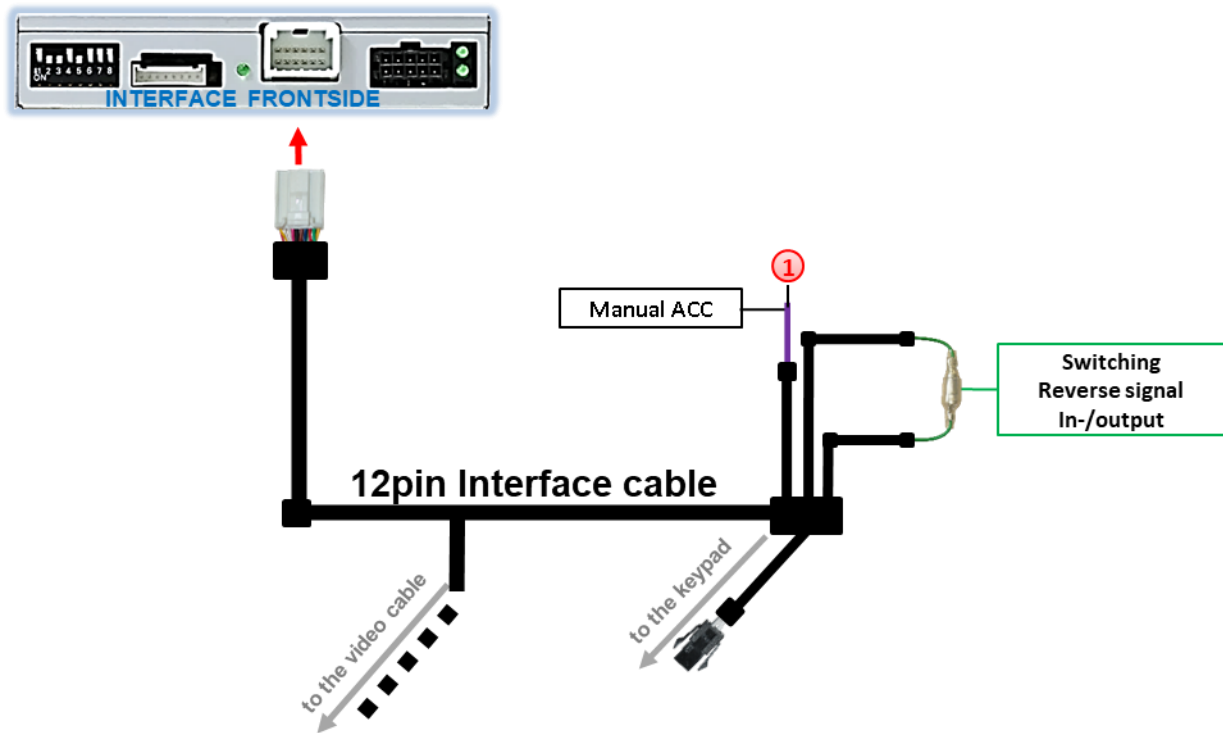

- 1 If, after connecting the PNP harness, no interface LED lightens up while the ignition is turned on, the purple coloured wire **Manual ACC** of the 12pin interface cable has to be connected additionally to **ACC** or **S-contact terminal 86s +12V** (e.g. glove compartment illumination).

2.3. Power supply output

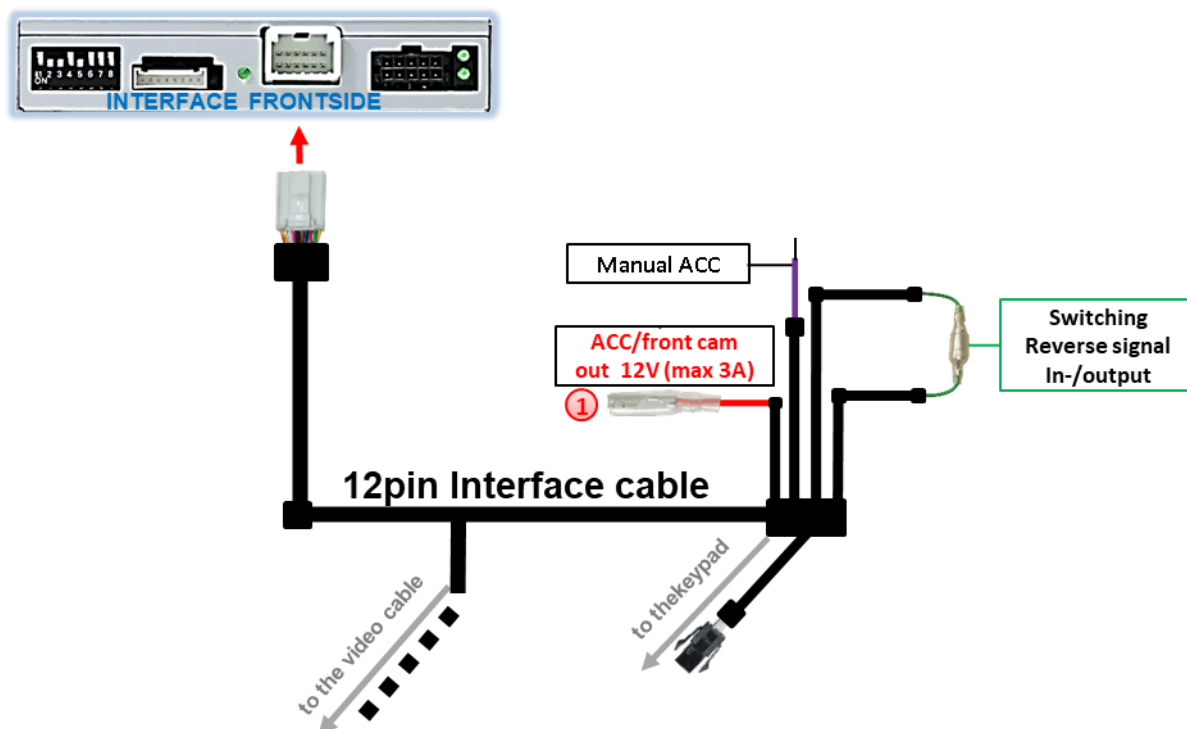

- ① The red power supply output **ACC/front cam out 12V (max 3A)** can be used to power an external source and has a different assignment depending on the position of dip switch 1 (of the black 8 dips):

| Dip | Function |
|-----------|--|
| Dip 1 ON | +12V (max. 3A) when reverse gear is engaged incl. 10 seconds delay after reverse gear is disengaged and +12V by manual switching to front camera by keypad (short press) |
| Dip 1 OFF | +12V (max. 3A) ACC |

2.4. Connection - video sources

It is possible to connect an after-market rear-view camera, an after-market front camera and two more video sources to the video-interface.

Before a final installation of the video sources, we recommend a test-run to ensure the compatibility of vehicle and interface. Due to changes in the production of the vehicle manufacturer there's always a possibility of incompatibility.

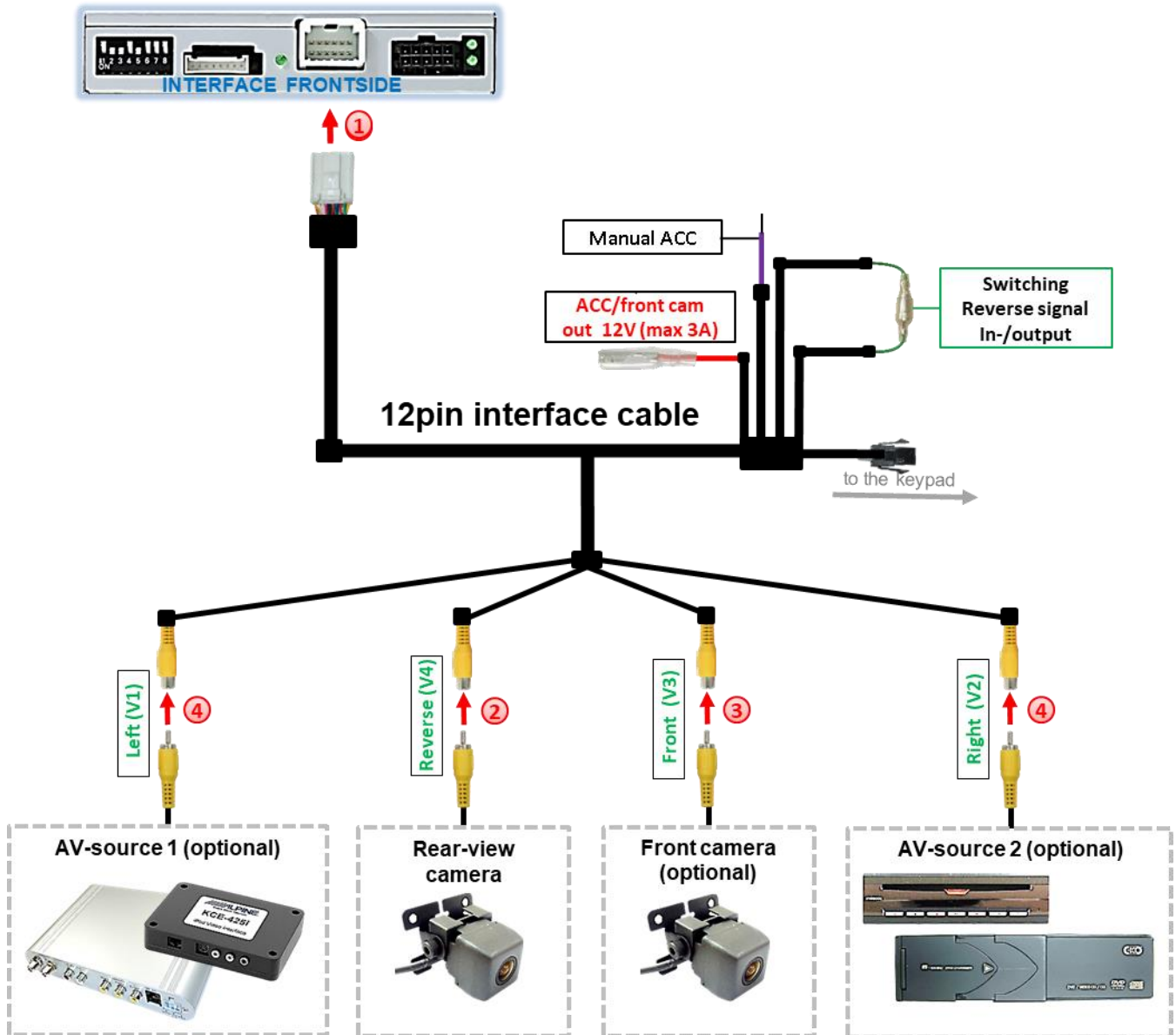

- 1 Connect the 12pin interface cable's female 12pin connector to the male 12pin connector of the video-interface.
- 2 Connect the video RCA of the Rear-view camera to the 12pin interface cable's female RCA connector „Reverse V4“.
- 3 Connect the front camera's video RCA connector to the 12pin interface cable's female RCA connector „Front V3“.
- 4 Connect the video RCA of the AV source 1 and 2 to the 12pin interface cable's female RCA connector “Left (V1)” and “Right (V2)”.

2.4.1. Audio-insertion

This interface is only able to insert video signals into the factory infotainment. If an AV-source is connected, the audio insertion has to be done by the factory audio AUX input or an FM-modulator. The inserted video-signal can be activated simultaneously to each audio-mode of the factory infotainment. If 2 AV sources shall be connected to the infotainment, additional electronic is necessary to switch the audio signals.

2.4.2. After-market front camera

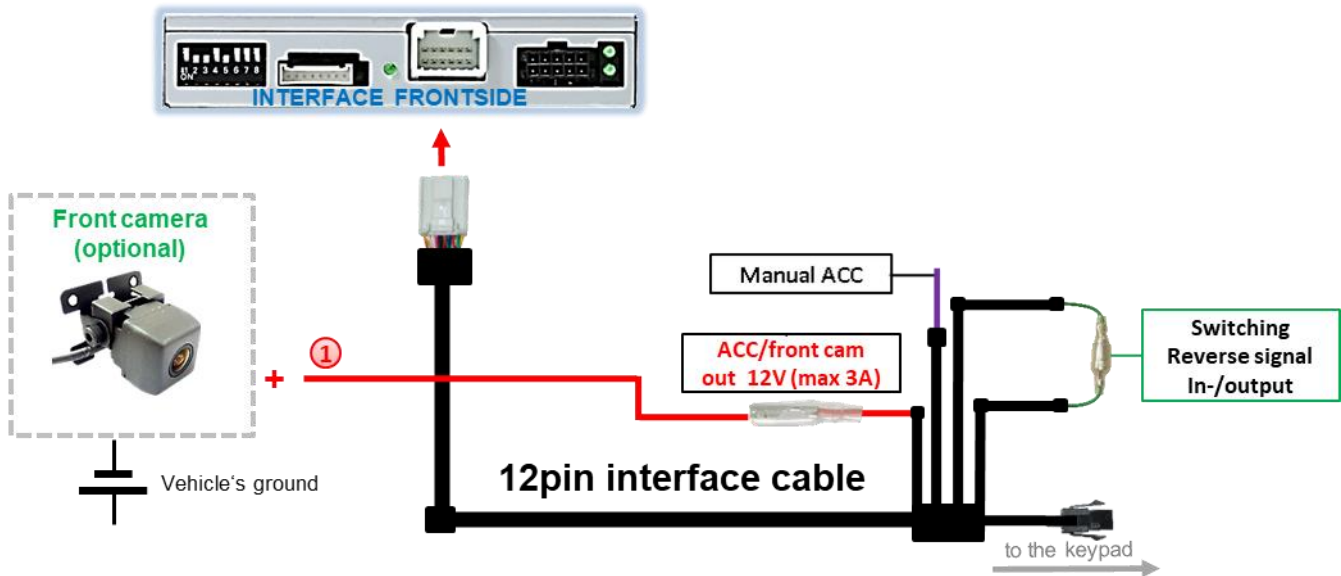

- ① The red power supply output **ACC/front cam out 12V (max 3A)** can be used to power a front camera. If Dip 1 is set to ON (black 8 dips), the power supply output gives +12V (max 3A) when reverse gear is engaged incl. 10 seconds delay after reverse gear is disengaged.

Note: In addition, a manual switch-over to the front camera input is possible via keypad (short press) from any image mode. The power supply output gives +12V then, as well (if Dip 1 is set to ON and the front camera input is selected).

Attention: A long press of the external keypad push button will switch the interface to the next source.

2.4.3. After-market rear-view camera

Some vehicles have a different reverse gear code on the CAN-bus which the video-interface is not compatible with. Therefore, there are two different ways of installation. If the video interface receives a signal of the reverse gear, the green wire **“Reverse-OUT”** of the 20pin cable should carry +12V while the reverse gear is engaged.

Note: Do not forget to set video interface’s dip5 to ON before testing.

2.4.3.1. Case 1: Interface receives the reverse gear signal

If the interface delivers +12V on the green output wire of the 12pin interface cable while reverse gear is engaged, the video interface will automatically switch to the rear-view camera input **“Camera IN”** while the reverse gear is engaged.

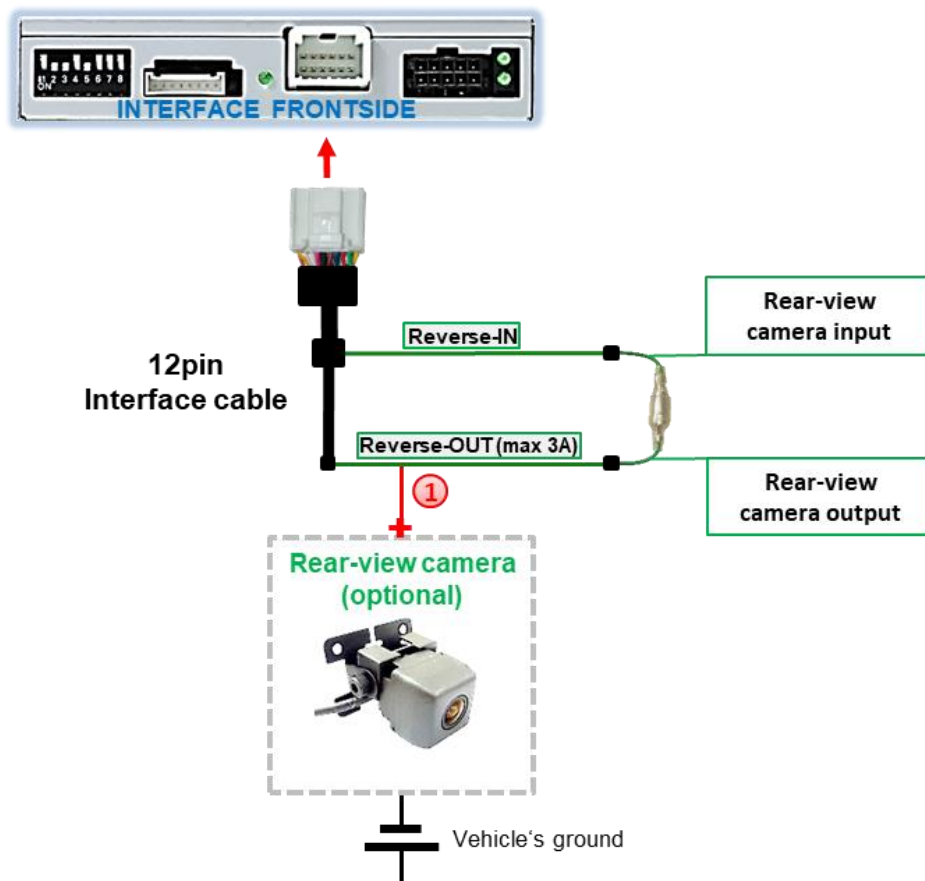

- ① Additionally, the +12V (max. 3A) power supply for the rear-view camera can be taken from the green wire of the 12pin interface cable.

2.4.3.2. Case 2: Interface does not receive the reverse gear signal

If the video interface does not deliver +12V on the green wire of the 12pin cable when reverse gear is engaged (not all vehicles are compatible), an external switching signal from the reverse gear light is required. As the reverse gear light's power supply isn't voltage-stable all the time, an ordinary open relay (e.g AC-RW-1230 with wiring AC-RS5) or filter (e.g. AC-PNF-RVC) is required. The diagram below shows the connection type of the relay.

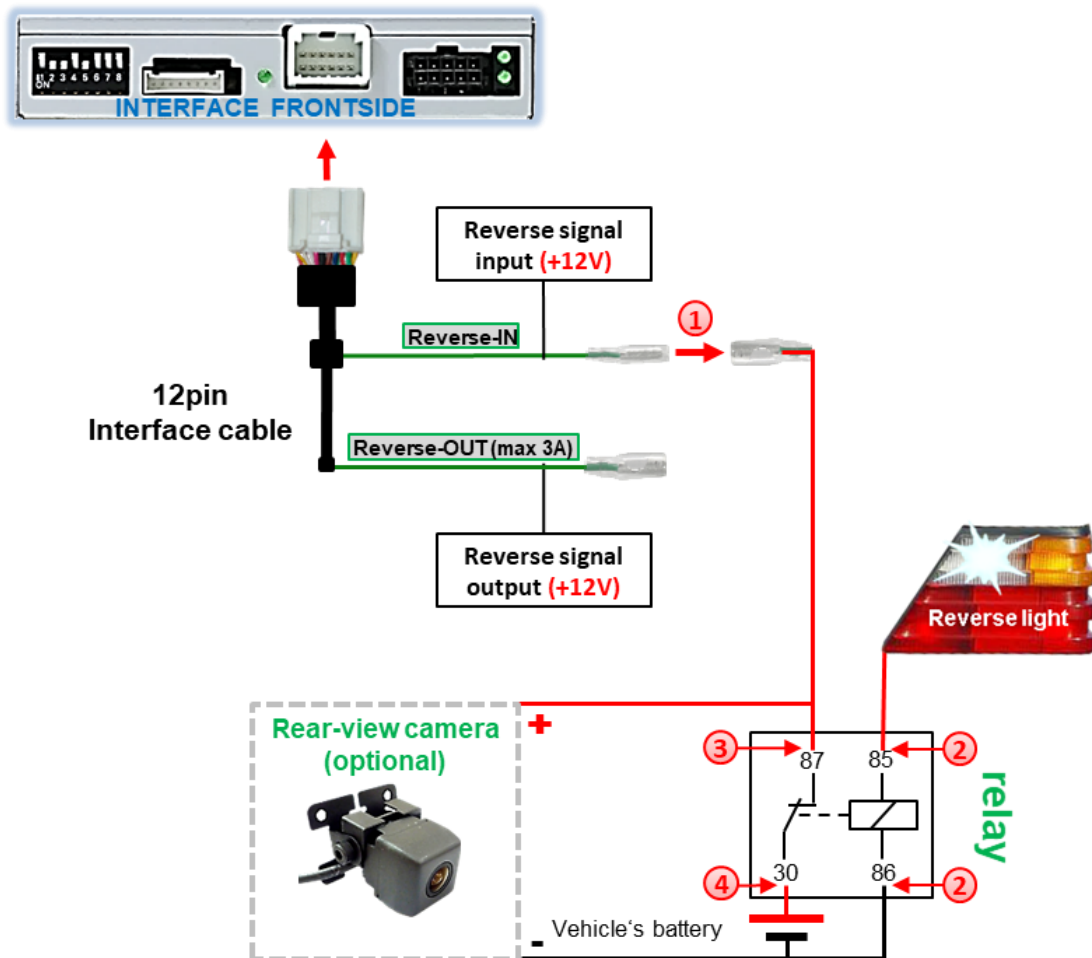

- 1 Disconnect the green cable's preconnected male- and female connectors of the 12pin interface cable and connect the green input cable "Reverse-IN" to the output connector (87) of the relay.

Note: Last but not least to avoid short circuits, the best solution should be, to crimp a male 4mm connector to the relay's output cable and connect it to the green cable's female 4mm connector. The output-cable "Reverse-OUT" remains disconnected as it's out of function.

- 2 Connect the Reverse light's power-cable to coil (85) and the vehicle's ground to coil (86) of the relay.
- 3 Connect the output connector (87) of the relay to the rear-view camera's power-cable, like you did it to the green "Reverse-IN" cable before.
- 4 Connect stable and permanent +12V to the relay's input connector (30).

2.5. Connection - video-interface and keypad

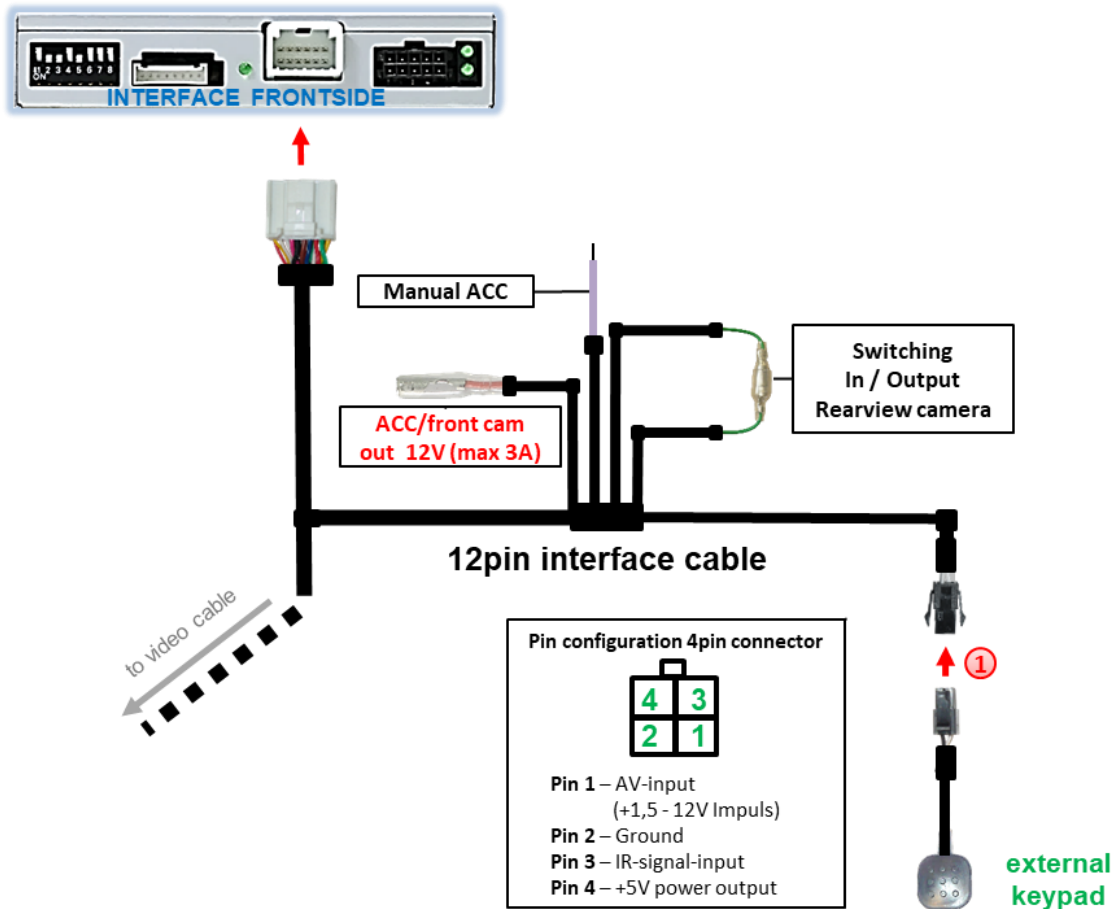

- 1 Connect the female 4pin connector of the keypad to the male 4pin connector of the 12pin interface cable.

Note: Even if switching through several video sources by the keypad mightn't be required, the invisible connection and availability is strongly recommended.

2.6. Picture -, guide-lines- and PDC settings

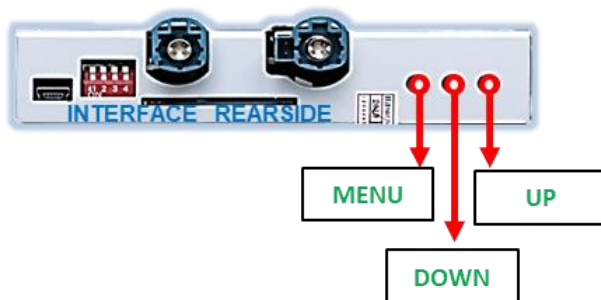

The picture settings are adjustable by the 3 push-buttons at the rear-side of the video-interface. Press the MENU button to open the OSD settings menu or to switch to the next menu item. Press UP and DOWN to change the selected value. The buttons are placed inside in the housing to avoid accidental changes during or after the installation. Picture settings must be done separately for all video inputs while the corresponding input is selected and visible on the monitor.

Note: The OSD menu is only shown when a working video source is connected to the selected video-input of the interface.

The following settings are available:

- Contrast
- Brightness
- Saturation
- Position H* (horizontal)
- Position V* (vertical)
- H-SIZE (Image width)
- V-Size (Picture height)

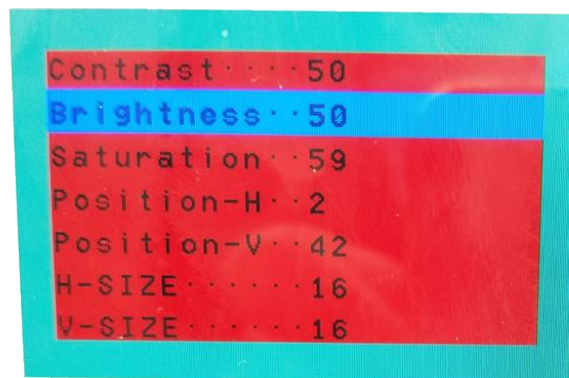

*If the vertical and horizontal picture position is not shown correctly on the display, it can only be adjusted in the menu if Dip-8 (the black 8-dips) was previously set to ON.

Note: If the video interface does not receive the required information from the vehicle CAN-bus, neither moving guide-lines nor PDC will be supported.

3. Interface operation

3.1. By factory infotainment button



To switch the sources

Pressing the “Home” infotainment key, switches the interface’s activated video sources.

If all inputs are activated by dip switch settings, the order is the following:



Each striking-off will switch to the next enabled input. Inputs which are not enabled will be skipped.

Switchover by infotainment buttons isn't possible in all vehicles. In some vehicles the external keypad has to be used.

3.2. By keypad

Alternatively or additionally to the factory infotainment buttons, the interface's external keypad can be used to switch the enabled inputs. Even if not needed, the keypad should always remain connected to the video interface for support purposes.

➤ Long press of keypad (2-3 seconds)

By long pressing the external keypad (2-3 seconds), the video interfaces switches the input from the factory video to the inserted video sources. Each long press will switch to the next enabled input. Inputs which are not enabled will be skipped.

Note: The interface switches after releasing the switch (after long pressure).

➤ Short press of keypad (only if DIP 1 is set to ON)

By short pressing the external keypad, the video interfaces switches from the factory video to the front camera input and back to factory video.

4. Specifications

| | |
|----------------------|-------------------------------|
| BATT/ACC range | 7V - 25V |
| Stand-by power drain | 7mA |
| Power | 300mA @12V |
| Video input | 0.7V - 1V |
| Video input formats | NTSC and PAL |
| Temperature range | -40°C to +85°C |
| Dimensions video-box | 116 x 25 x 103 mm (W x H x D) |

5. FAQ – Trouble shooting Interface functions

For any troubles which may occur, check the following table for a solution before requesting support from your vendor.

| Symptom | Reason | Possible solution |
|--|---|---|
| No picture/black picture (factory picture). | Not all connectors have been reconnected to factory head-unit or monitor after installation. | Connect missing connectors. |
| | No power on CAN-bus box (all LED CAN-bus box are off). | Check power supply of CAN-bus box. Check CAN-bus connection of CAN-bus box. |
| | CAN-bus box connected to CAN-bus in wrong place. | Refer to the manual where to connected to the CAN-bus. If not mentioned, try another place to connect to the CAN-bus. |
| | No power on video-interface (all LED video-interface are off). | Check whether CAN-bus box delivers +12V ACC on red wire output of 8pin to 6pin cable. If not cut wire and supply ACC +12V directly to video-interface. |
| No picture/black picture/white picture (inserted picture) but factory picture is OK. | No picture from video source. | Check on other monitor whether video source is OK. |
| | No video-source connected to the selected interface input. | Check settings dips 1 to 3 of video interface which inputs are activated and switch to corresponding input(s). |
| | LVDS cables plugged in wrong place. | Double-check whether order of LVDS cables is exactly connected according to manual. Plugging into head-unit does not work when the manual says to plug into monitor and vice versa. |
| Inserted picture totally wrong size or position. | Wrong monitor settings of video-interface. | Try different combinations of dips 7 and 8 of video-interface. Unplug 6pin power after each change. |
| Inserted picture double or 4 times on monitor. | | |
| Inserted picture distorted, flickering or running vertically. | Video sources output set to AUTO or MULTI which causes a conflict with the interfaces auto detection. | Set video source output fixed to PAL or NTSC. It is best to set all video sources to the same standard. |
| | If error occurs only after source switching: Connected sources are not set to the same TV standard. | Set all video sources to the same standard. |
| | Some interfaces can only handle NTSC input. | Check manual whether there is a limitation to NTSC mentioned. If yes, set source fixed to NTSC output. |
| Inserted picture b/w. | Picture settings have not been adjusted. | Use the 3 buttons and the interface's OSD to adjust the picture settings for the corresponding video input. |
| Inserted picture qual. bad. | | |
| Inserted picture size slightly wrong. | | |
| Inserted picture position wrong. | | |
| Camera input picture flickers. | Camera is being tested under fluorescent light which shines directly into the camera. | Test camera under natural light outside the garage. |
| Camera input picture is bluish. | Protection sticker not removed from camera lens. | Remove protection sticker from lens. |

| Symptom | Reason | Possible solution |
|---|---|--|
| Camera input picture black. | Camera power taken directly from reverse gear lamp. | Use relay or electronics to "clean" reverse gear lamp power. Alternatively, if CAN-bus box is compatible with the vehicle, camera power can be taken from green wire of 6pin to 8pin cable. |
| Camera input picture has distortion. | | |
| Camera input picture settings cannot be adjusted. | Camera input picture settings can only be adjusted in AV2 mode. | Set dip 3 of video-interface to ON (if not input AV2 is not already activated) and connect the camera to AV2. Switch to AV2 and adjust settings. Reconnect camera to camera input and deactivate AV2 if not used for other source. |
| Graphics of a car in camera input picture. | Function PDC is ON in the interface OSD. | In compatible vehicles, the graphics will display the factory PDC distance. If not working or not wanted, set interface OSD menu item UI-CNTRL to ALLOFF. |
| Chinese signs in camera input picture | Function RET or ALL is ON (function for Asian market) in the interface OSD. | Set interface OSD menu item UI-CNTRL to ALLOFF or PDCON. |
| Not possible to switch video sources by OEM button. | CAN-bus interface does not support this function for vehicle. | Use external keypad or cut white wire of 6pin to 8pin cable and apply +12V impulses for AV-switching. |
| Not possible to switch video sources by external keypad. | Pressed too short. | For video source switching a longer press of about 2.5 seconds is required. |
| | SW-version of interface does not support external keypad. | Use OEM-button or cut white wire of 6pin to 8pin cable and apply +12V impulses for AV-switching. |
| Interface does not switch to camera input when reverse gear is engaged. | CAN-bus interface does not support this function for the vehicles. | Cut the green wire of the 6pin to 8pin cable and apply +12V constant from reverse gear-lamp signal. Use relay to "clean" R-gear lamp power. |
| Interface switches video-sources by itself. | CAN-bus interface compatibility to vehicle is limited. | Cut the grey wire of 6pin to 8pin and isolate both ends. If problem still occurs, additionally cut the white wire of 6pin to 8pin cable and isolate both ends. |

6. Technical Support

Please note that direct technical support is only available for products purchased directly from NavLinkz GmbH. For products bought from other sources, contact your vendor for technical support.

NavLinkz GmbH
distribution/tech dealer-support
 Heidberghof 2
 D-47495 Rheinberg

Tel +49 2843 17595 00
 Email mail@navlinkz.de

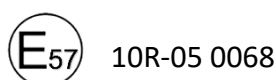

Made in China

